

VEMS ECU (Audi JPT55 connector), based on VEMS v3

Typically some cables and connectors (not in the JPT55 connector) are through the endplate.

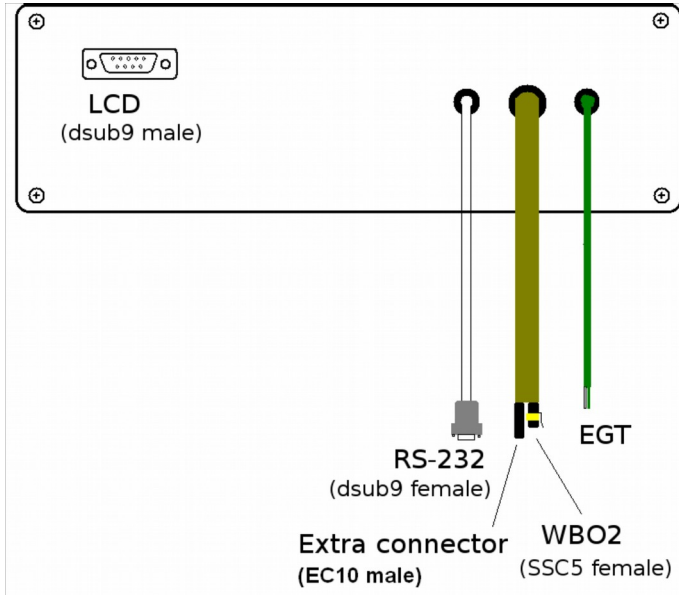

WBO2 controller is for Bosch LSU4.9 (controller is also compatible with LSU4.2 sensor). Proper type must be selected in configuration

WBO2 (SSC5 female)

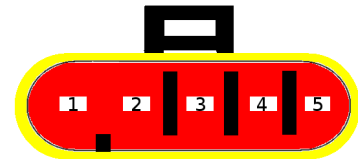

WBO2 connector pinout, LSU4.9 (preferred) or LSU4.2

SSC5	LSU4.9	LSU4.2	Name	Wirecolor (Bosch)	Old Color
1	6	1	nernst	black	black
2	4	3	supply+12V	grey	Thick red !
3	3	4	heater(-)	white	Thick brown
4	2	5	pump(-)	yellow	blue
5	1	6	pump(+)	red	Thin red

Beware: misconnection (eg. plugging RS232 into LCD connector, or voltage outside 0 .. +5V on EC10 analog inputs) might damage the device.

```

Board_version=          v3.8
Serial_nr=
wbo2_pump_pw_zero=
wbo2_nernstdc_target=
egt1_cal=
batt_cal=
MAT type                PTC (factory PTC sensor)    NTC (NTC sensor)
Trigger                 VR/audittrigger             HALL/HALL
Knock input channels    2                            0
    
```

Oid:

Date: